

CBZ-10

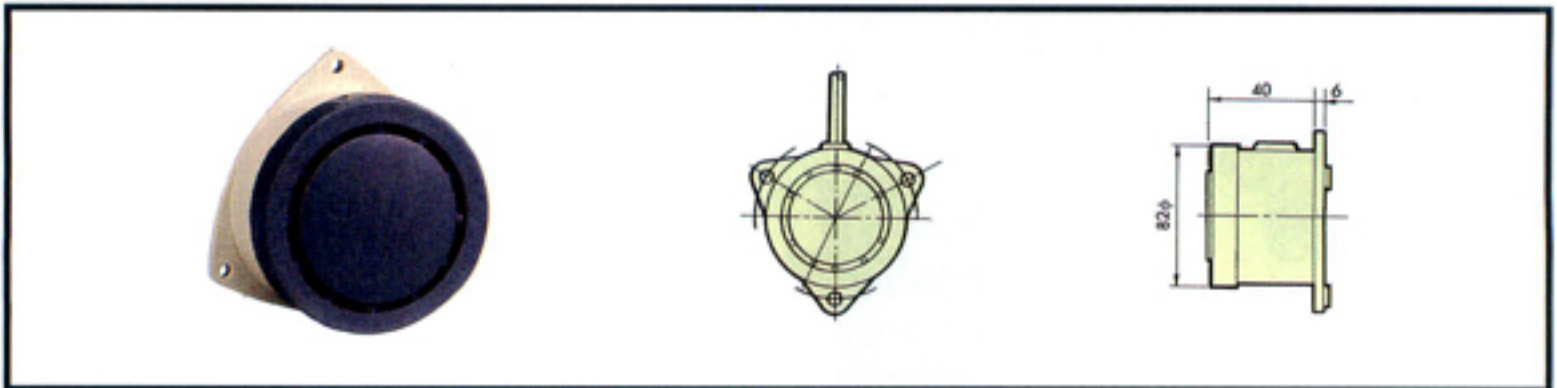

CBZ-20

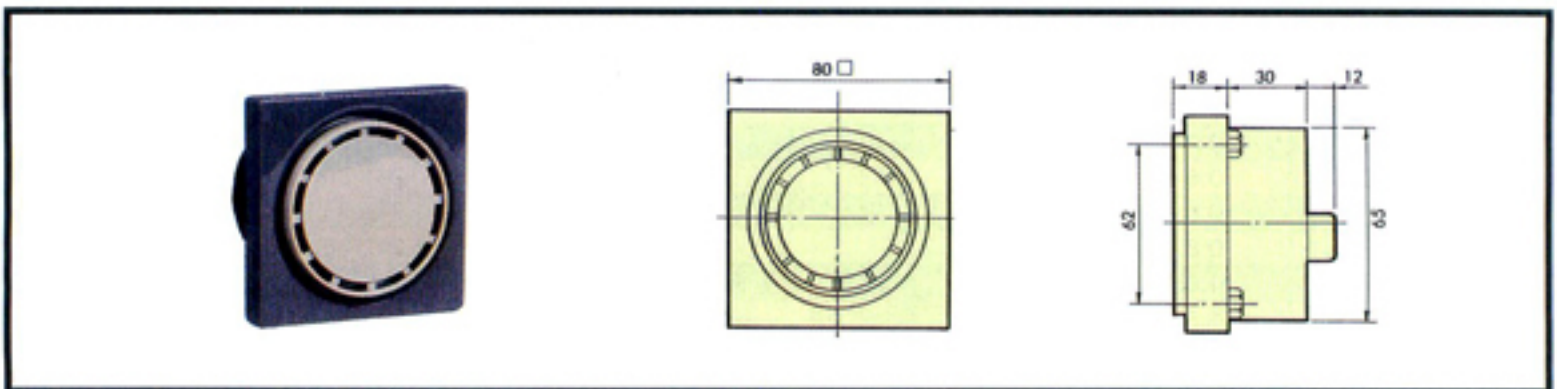

CBZ-30

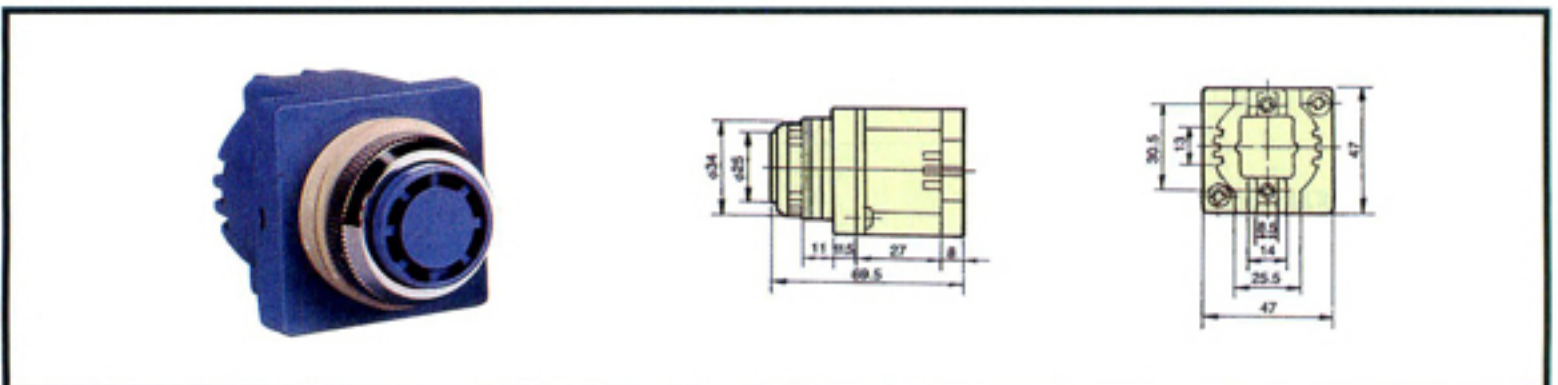

SPECIFICATIONS

TYPE	RATING	MOUNTZNG STYLE	VOLUME(D.B)	WEIGHT
CBZ-10	AC 110V ● 220V ● 380V DC 12V ● 24V	SURFACE MOUNTING	80	160g
CBZ-20	AC 110V ● 220V ● 380V DC 12V ● 24V	FLUSH MOUNTING	80	190g
CBZ-30	AC 110V ● 220V DC 12V ● 24V	FLUSH MOUNTING	40	125g