

61F-G1 FLOATLESS LEVEL SWITCH



■ OPERATION

- ① For Prevention of Pump Idling : When the liquid level in the water tank reaches E1(high) the motor is turned off, and when the level drops below E2(medium) it is turned on.
- ② For Prevention of Pump Idling : The motor is automatically turned off, when the liquid at the water supply source is in shortage and drops below the level of E2 (medium). An alarm is then sounded.
- ③ Issuance of Alarm for Abnormal Water Shortage : The motor is automatically turned off when for any reason the liquid level in the water tank drops below E2 (low). An alarm is then sounded.
- ④ Liquid level control is conducted within the range between the tips of E1 (high) and E2 (medium) in the water tank. Therefore, by changing the length of electrodes the range of control can be freely adjusted.
- ⑤ However, depending on the type of liquid and voltage variation, a slight difference is noted of the level where the pump resumes operation after the liquid level has reached the tip of the electrode.
- ⑥ Insert a pushbutton switch (NO contact) between E1' and E3 as shown by the dotted line on the light.
In starting pump or after recovery from power failure, if water supply source level has not yet reached E1', depress the pushbutton switch to start the pump by momentarily short-circuiting E1' and E3.
When the pump stops during normal operation subsequent to an alarm issued for low water level (water level does not reach E2'), do not depress the pushbutton switch.

■ **Warning** : Note the difference in the wiring between the automatic water supply control with prevention of pump idling and that with issuance of alarm for abnormal water shortage.

EXTERNAL CONNECTION EXAMPLE

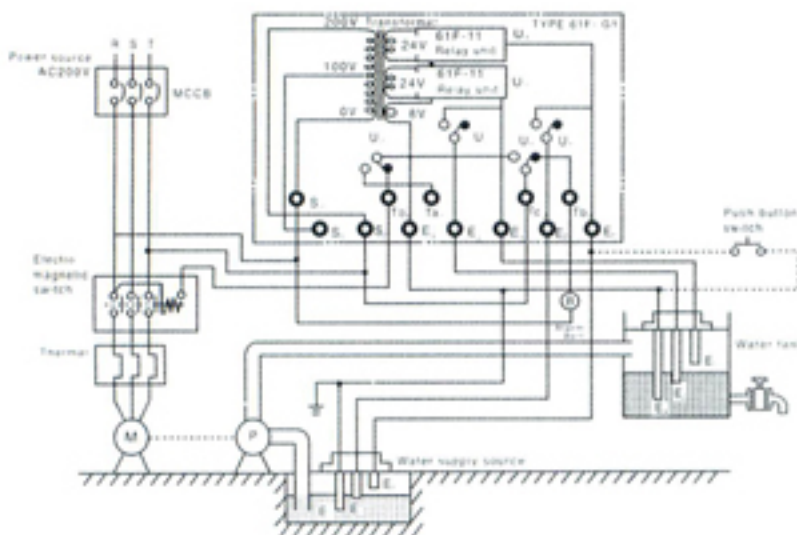

- With the power supply voltage 100V (110, 120V), the wiring is made between S0-S1 and with 200V (220, 240V) S0-S2.
- Be sure to ground terminal E3

PARTS USED FOR 61F-G1



SUS-S
connecting



PS-3S
Electrode Holder



PS-3S & SUS-A
Electrode Rod
(SUS-A)